

ABU Federleitungstrommel 280 E

(mit höherer Federkraft)

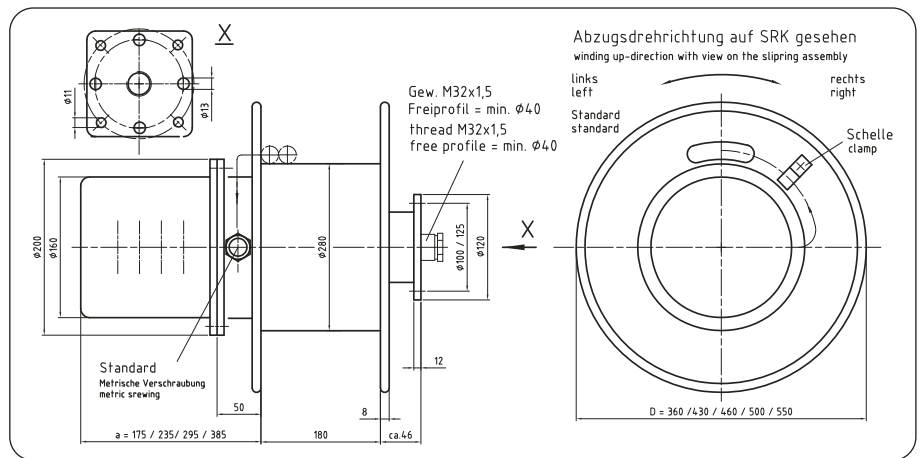

- Bordscheiben, Befestigungsflansch und Trommelkörperkern verzinkt und zusätzlich polyesterpulverbeschichtet
- Schleifringkörpergehäuse aus Kunststoff
- Aufwickelgeschwindigkeit: max. 63 m/min horizontal, max. 40 m/min vertikal
- Beschleunigung: max. 0,3 m/s²
- Leitungsdurchmesser: max. 24 mm
- Aufzuwickelnde Leitungslänge: max. 60 m horizontal, max. 27 m vertikal
- Leitungsgewicht: max. 0,80 kg/m

Trommeltypen für Baureihe 280 E

Kenn Nr.	Trommel Typ	d Ø	D Ø	b	Za	Fa	Fe	Z	n.vor	N.Res.	n.Umdr.	Gewicht (kg)
1	28361810E	280	360	180	7,1	6,8	17,5	19,0	3,0	1,5	17,5	22,5
2	28431810E	280	430	180	7,1	6,8	17,5	19,0	3,0	1,5	17,5	23,5
3	28431820E	280	430	180	7,1	6,8	17,5	19,0	6,0	3,0	35,0	30,0
4	28551820E	280	550	180	7,1	6,8	17,5	19,0	6,0	3,0	35,0	31,0
5	28431830E	280	430	180	7,1	6,8	17,5	19,0	9,0	4,5	52,5	33,5
6	28501830E	280	500	180	7,1	6,8	17,5	19,0	9,0	4,5	52,5	34,0
7	28551830E	280	550	180	7,1	6,8	17,5	19,0	9,0	4,5	52,5	34,5
8	28431840E	280	430	180	7,1	6,8	17,5	19,0	12,0	6,0	70,0	39,5
9	28552140E	280	550	215	7,1	6,8	17,5	19,0	12,0	6,0	70,0	40,5
10	28551822E	280	550	180	14,0	13,5	35,0	38,0	6,0	3,0	35,0	40,5

